



Gas Griddle Manual & Thermostatic Control

Specifications

The NOVA Countertop Griddle is available in both Manual or Thermostatic Control. The griddle plate, with its efficient $\frac{3}{4}$ " thickness, provides uniform heat distribution, and it incorporates NOVA's "quick on" feature. This feature activates the burners as soon as temperature drops are detected by the probes. This gives you important quick temperature recovery when cooking. The result is faster cook times, greater moisture retention, and higher product yield. It is available in 24", 36", and 48" widths. Units are shipped for natural gas but are easily converted to LP (propane) gas with the LP conversion kit that is included.

All Griddles carry ETL gas and sanitation approvals that pass US gas and sanitation requirements for use in restaurants.

Model	Burners
GR-24 / GR-24-T	2
GR-36 / GR-36-T	3
GR-48 / GR-48-T	4



Features

- High Performance and Efficient 30,000 BTU Stainless Steel U style burners provide flame every 6" on the griddle surface
- $\frac{3}{4}$ " Highly Polished griddle plate providing even heat distribution
- 4" High Backsplash and Sidesplash fully welded to the griddle
- Double wall construction with insulated side panels
- Extended cool to-touch front edge
- Thermostatic Griddle available with 200 °F to 450 °F temperature range
- Wide $3\frac{1}{4}$ " front grease trough
- Removable, easy-to-clean stainless grease catch pan
- Large temperature knobs with set screws
- Pilots with front access
- Adjustable nonskid Stainless Steel legs

- All units come natural gas with a propane conversion kit. Gas regulator included.

Warranty: 1-year parts and labor

*Not suitable for installation in a non-commercial or residential applications.



Gas Griddle Manual & Thermostatic Control

DETAILS AND DIMENSIONS

- A pressure regulator is provided with this unit.
Natural Gas 4.0" W.C.
Propane Gas 10.0" W.C
- Gas connection is 3/4" NPT (19mm) rear gas connection.
- All equipment is supplied for Natural Gas, an LP conversion kit is also provided.

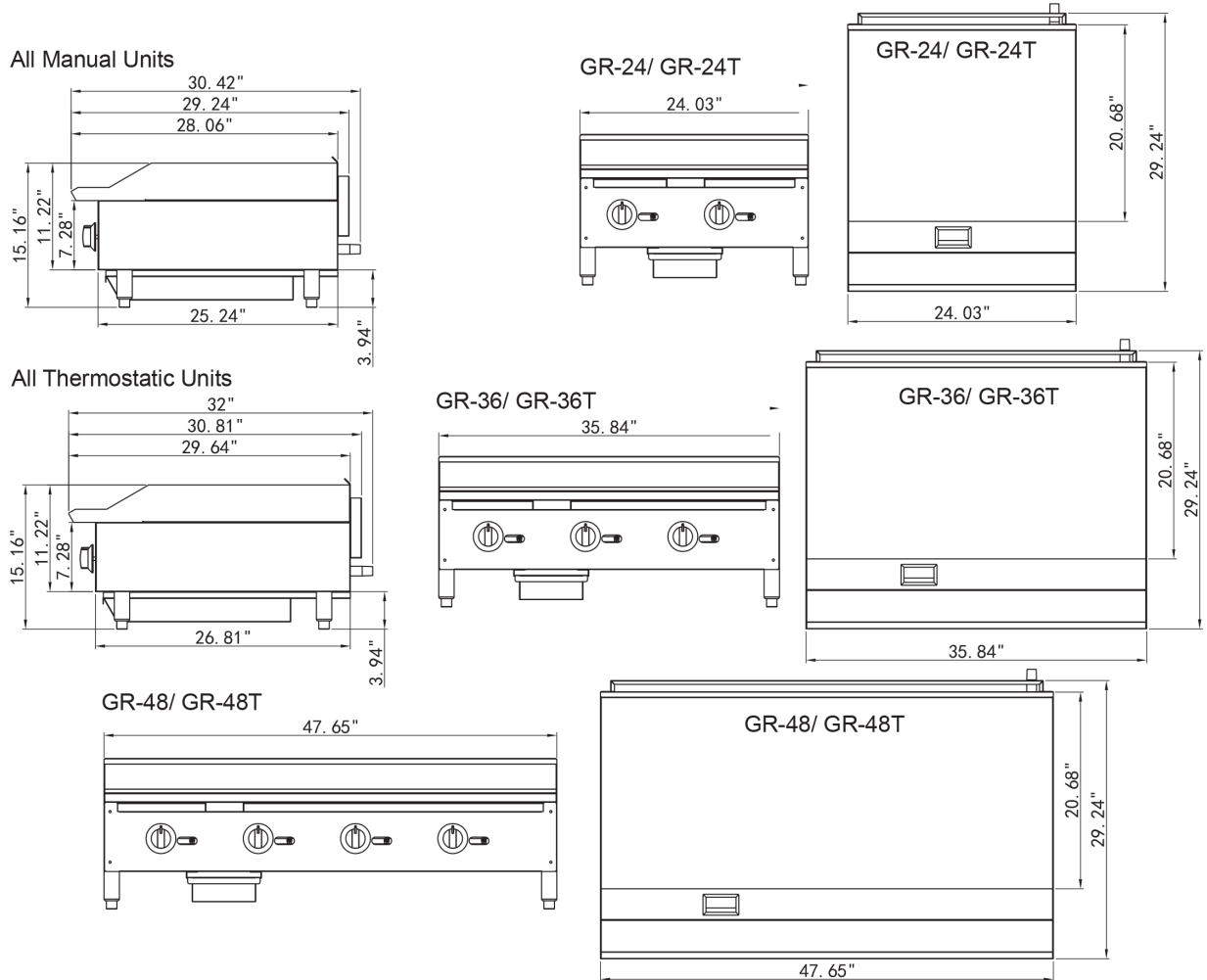

	Model	Burners	Cooking Area		Plate Thickness	Dimensions			BTU's (per burner)	Total BTU's	Crated Weight (lbs)
			L	W		W	D	H			
Manual Units	GR-24	2	20.68	23.97	3/4"	24.03	29.24	15.16	30,000	60,000	198
	GR-36	3	20.68	35.78	3/4"	35.84	29.24	15.16	30,000	90,000	274
	GR-48	4	20.68	47.59	3/4"	47.65	29.24	15.16	30,000	120,000	352
Thermostatic Units	GR-24-T	2	20.68	23.97	3/4"	24.03	29.24	15.16	30,000	60,000	198
	GR-36-T	3	20.68	35.78	3/4"	35.84	29.24	15.16	30,000	90,000	274
	GR-48-T	4	20.68	47.59	3/4"	47.65	29.24	15.16	30,000	120,000	352